

Wellposedness for Systems Arising in Time Domain Electromagnetics in Dielectrics

H. T. Banks and J. M. Bardsley *

July 4, 2003

Abstract

We present wellposedness results for a multi-dimensional electromagnetic interrogation problem involving Maxwell's equations in variational form coupled with general polarization equations and perfectly matched layers (PMLs) at finite boundaries.

1 Introduction

In this paper we present theoretical foundations (existence, uniqueness, continuous dependence) for a particular two dimensional Maxwell system. This system is a multi-dimensional version of the one dimensional systems treated in [2, Chapter 3]. The 2-D problem, carefully formulated and treated numerically in [1], arises from pulsed microwaves emanating from a semi-infinite strip of a finite antenna, producing obliquely incident waves on a dielectric material target as depicted in Figure 1. The problem is formulated with distributional (in space) input currents, a general convolution polarization relationship that includes most models for dielectrics currently found in the literature, and a finite computational domain with partially absorbing boundary conditions as well as perfectly matched layers (PMLs) to attenuate incident energy at the boundaries. The resulting system involves a second order (in time) Maxwell's equation in variational form, coupled with the polarization convolution and PML constraint equations most conveniently formulated in terms of distributions and convolutions. While we follow the general approach to a theoretical framework developed in [2], the multi-dimensional aspects of the electric field as well as that of the computational domain with PML boundaries present new theoretical challenges. We provide arguments here to successfully overcome these difficulties and establish new wellposedness results.

*Center for Research in Scientific Computation, North Carolina State University, Raleigh, NC 27695-8205, and Statistical and Applied Mathematical Sciences Institute, Research Triangle Park, NC 27709-4006.

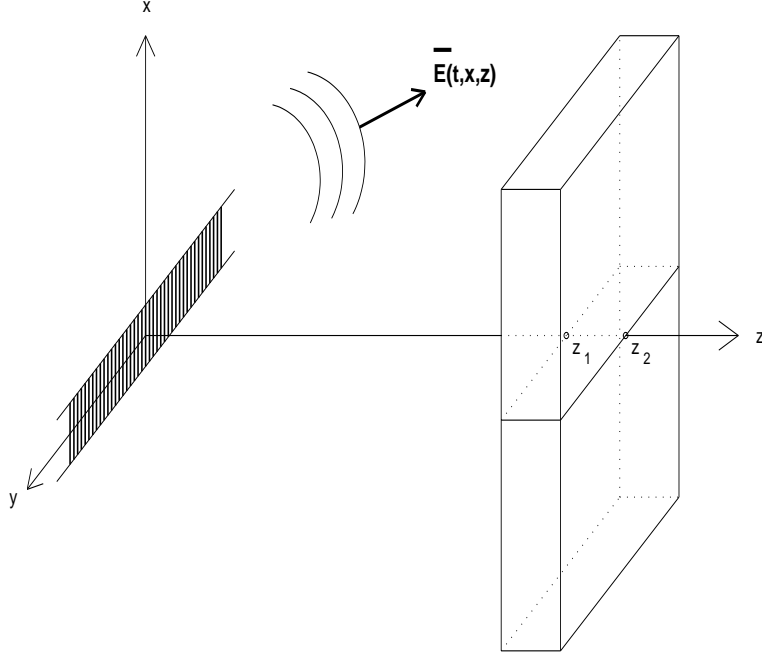

Figure 1: Infinite strip antenna and dielectric slab.

2 Formulation of Problem

In this section we provide an overview of the derivation of the wave equation of interest given in [1]. Maxwell's equations for a region with free charge density $\rho = 0$ are given by

$$\begin{aligned}
 \nabla \cdot \vec{D} &= 0 \\
 \nabla \cdot \vec{B} &= 0 \\
 \nabla \times \vec{E} &= -\partial_t \vec{B} \\
 \nabla \times \vec{H} &= \partial_t \vec{D} + \vec{J},
 \end{aligned} \tag{1}$$

where the vectors in (1) are functions of position $\vec{r} = (x, y, z)$ and time t , and $\vec{J} = \vec{J}_c + \vec{J}_s$, where \vec{J}_c is the conduction current density and \vec{J}_s is the source current density. We assume only free space can have a source current, and thus either $\vec{J}_c = \vec{0}$ or $\vec{J}_s = \vec{0}$, depending on whether or not the region is free space.

In order to allow for a diagonally anisotropic medium, we use the diagonal operator

$$T = \text{diag}(T_x, T_y, T_z).$$

Here, given $f \in C[0, \infty)$, $T_i f \stackrel{\text{def}}{=} g_i * f$ for $i = x, y, z$, where g_i is a tempered distribution as

described in [1]. The diagonally anisotropic material constitutive relations are then given by

$$\begin{aligned}\vec{D} &= g * (T\vec{E}) \\ \vec{B} &= \mu_0 T \vec{H} \\ \vec{J}_c &= \sigma T \vec{E},\end{aligned}\tag{2}$$

where g is a tempered distribution, convolution is in the time variable, μ_0 is the magnetic permeability of free space, and the constant $\sigma > 0$ is the conductivity arising in Ohm's law.

By restricting our attention to a region Ω on which T and g are constant, using (2) and (1), and defining the electric polarization vector \vec{P} by

$$g \star \vec{E} = \epsilon_0 \epsilon_r \vec{E} + \vec{P},\tag{3}$$

where ϵ_r is the relative permittivity, we obtain the wave equation

$$\mu_0 \epsilon_0 \epsilon_r \ddot{\vec{E}} + \mu_0 \ddot{\vec{P}} + \mu_0 \sigma \dot{\vec{E}} - (\nabla \cdot (\tilde{T} \nabla)) \vec{E} = -\mu_0 T^{-1} \dot{\vec{J}}_s,\tag{4}$$

where $\dot{} = \partial_t$, $\ddot{} = \partial_t^2$, and

$$\tilde{T} = (T_x T_y T_z)^{-1} T.\tag{5}$$

We now express equation (4) in variational form. Let Ω have a piecewise smooth boundary, and let ϕ be a test function on Ω . For a function f on Ω define

$$\langle f, \phi \rangle = \int_{\Omega} f(\vec{r}) \phi(\vec{r}) dV.$$

If f and ϕ are also defined on $\partial\Omega$ let

$$\langle f, \phi \rangle_{\partial\Omega} = \int_{\partial\Omega} f(\vec{r}) \phi(\vec{r}) ds.$$

Let \vec{u} equal one of the standard basis vectors \hat{x} , \hat{y} , or \hat{z} , and define

$$\begin{aligned}E &= \vec{E} \cdot \vec{u} \\ P &= \vec{P} \cdot \vec{u} \\ J_s &= (T^{-1} \vec{J}_s) \cdot \vec{u}.\end{aligned}\tag{6}$$

The variational, or weak, formulation of (4) is then given by

$$\begin{aligned}\mu_0 \epsilon_0 \langle \epsilon_r \ddot{\vec{E}}, \phi \rangle + \mu_0 \langle \ddot{\vec{P}}, \phi \rangle + \mu_0 \langle \sigma \dot{\vec{E}}, \phi \rangle + \sum_{i=x,y,z} \langle \partial_i (\tilde{T}_i E), \partial_i \phi \rangle - \sum_{i=x,y,z} \langle \partial_i (\tilde{T}_i E), n_i \phi \rangle_{\partial\Omega} \\ = -\mu_0 \langle \dot{\vec{J}}_s, \phi \rangle.\end{aligned}\tag{7}$$

Note that T^{-1} has disappeared on the right side of (7). This is because in our problem a current source will only exist in free space where $T = I$. Hence the right side of (4) reduces to either 0 or $-\mu_0 \dot{\vec{J}}_s$.

Our computational domain \mathcal{D} will be the union of a finite number of regions Ω_k on which T and g are constant in the spatial variables. Hence, the components of a solution of Maxwell's equations with constitutive relations (2) will satisfy (7) on each Ω_k . To extend to the entire domain we must first determine \mathcal{D} . As in [1], we assume that E , P , and J_s are independent of y , so our computational domain is contained in the xz -plane. Let X and Z be closed intervals in the respective x - and z -axes, and let $\mathcal{D} = X \times Z$ denote the computational domain.

We partition the interval X into disjoint closed intervals X_- , X_0 , and X_+ such that

$$\begin{aligned} \max X_- &= \min X_0 \\ \max X_0 &= \min X_+, \end{aligned}$$

and partition the interval Z into disjoint closed intervals Z_- , Z_v , and Z_d such that

$$\begin{aligned} \max Z_- &= \min Z_v \\ \max Z_v &= \min Z_d. \end{aligned}$$

The regions Z_v and Z_d are the vacuum and dielectric regions respectively. Let

$$Z_0 = Z_v \cup Z_d.$$

The region $X_0 \times Z_0$ will be our domain of interest. The buffer region $\mathcal{D} \setminus (X_0 \times Z_0)$ outside our domain of interest will contain the PMLs. This problem geometry is illustrated in Figure 2.

We also need to choose an operator T . In order to guarantee zero reflection at the PML interfaces, T must be chosen carefully. In [1], T is taken to be

$$T = \begin{pmatrix} S_x^{-1} S_z & 0 & 0 \\ 0 & S_x S_z & 0 \\ 0 & 0 & S_x S_z^{-1} \end{pmatrix}, \quad (8)$$

where S_x and S_z are convolution operators on $C[0, \infty)$ with kernels

$$\begin{aligned} u_x(t, x) &= \delta(t) + \beta_x(x) \mathcal{H}(t), \\ u_z(t, z) &= \delta(t) + \beta_z(z) \mathcal{H}(t). \end{aligned} \quad (9)$$

Here δ is the Dirac delta function, \mathcal{H} is the Heaviside function, and both β_x and β_z are piecewise constant, convex functions such that $\beta_x = 0$ in X_0 and $\beta_z = 0$ in Z_0 . It is a straight forward exercise to show that

$$\tilde{T} = \text{diag}(S_x^{-2}, I, S_z^{-2}), \quad (10)$$

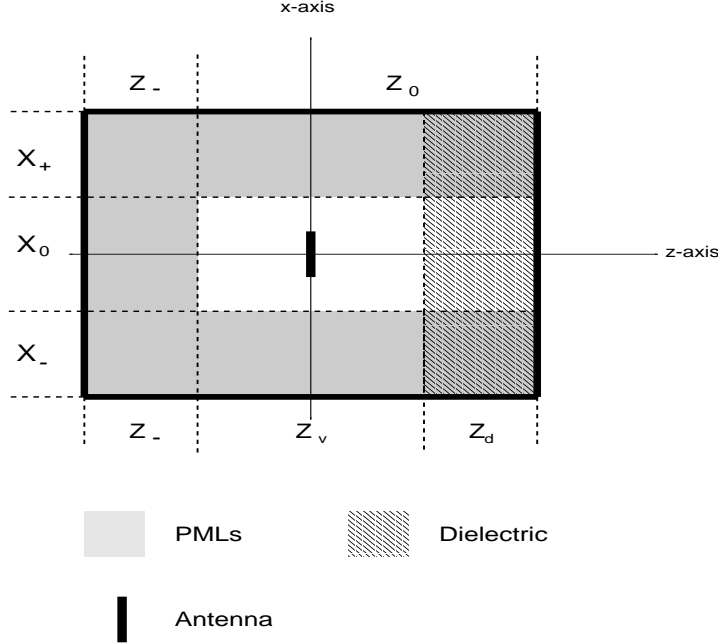

Figure 2: Computational domain.

where I is the identity operator, and S_x^{-1} and S_z^{-1} are convolution operators with kernels

$$\begin{aligned}
u_x^{-1}(t, x) &= \delta(t) - \beta_x(x)\mathcal{H}(t)e^{-\beta_x(x)t}, \\
u_z^{-1}(t, z) &= \delta(t) - \beta_z(z)\mathcal{H}(t)e^{-\beta_z(z)t}.
\end{aligned} \tag{11}$$

For computational reasons, V_x and V_y are introduced and are given by

$$\begin{aligned}
V_x + E &= \tilde{T}_x E \\
V_z + E &= \tilde{T}_z E.
\end{aligned} \tag{12}$$

Then, given the above comments, in any region Ω in which β_x and β_z are constant, the variational equation (7) can be written

$$\begin{aligned}
\mu_0 \epsilon_0 \langle \epsilon_r \ddot{E}, \phi \rangle + \mu_0 \langle \ddot{P}, \phi \rangle + \mu_0 \langle \sigma \dot{E}, \phi \rangle + \langle \partial_x(E + V_x), \partial_x \phi \rangle + \langle \partial_z(E + V_z), \partial_z \phi \rangle \\
- \langle \partial_x(E + V_x), n_x \phi \rangle_{\partial\Omega} - \langle \partial_z(E + V_z), n_z \phi \rangle_{\partial\Omega} = -\mu_0 \langle \dot{J}_s, \phi \rangle.
\end{aligned} \tag{13}$$

Provided that the PML parameters β_x and β_z are chosen carefully, it is argued in [1] that (13) will hold, to a sufficient degree of accuracy for computational purposes, on the computational domain \mathcal{D} . Then, the variational equation that is used for computations is given by

$$\begin{aligned}
\mu_0 \epsilon_0 \langle \epsilon_r \ddot{E}, \phi \rangle + \mu_0 \langle \ddot{P}, \phi \rangle + \mu_0 \langle \sigma \dot{E}, \phi \rangle + \langle \partial_x(E + V_x), \partial_x \phi \rangle + \langle \partial_z(E + V_z), \partial_z \phi \rangle \\
- \langle \partial_x(E + V_x), n_x \phi \rangle_{\partial\mathcal{D}} - \langle \partial_z(E + V_z), n_z \phi \rangle_{\partial\mathcal{D}} = -\mu_0 \langle \dot{J}_s, \phi \rangle.
\end{aligned} \tag{14}$$

Finally, we add absorbing boundary conditions. Let C_{-x} , C_{+x} , C_{-z} , and C_{+z} denote the four boundaries of \mathcal{D} with outward normals in the $-x$, $+x$, $-z$ and $+z$ directions respectively. We use the boundary conditions

$$\begin{aligned}(\beta_x + \partial_t)E &= c\partial_x E && \text{on } C_{-x} \\(\beta_x + \partial_t)E &= -c\partial_x E && \text{on } C_{+x} \\(\beta_z + \partial_t)E &= c\partial_z E && \text{on } C_{-z} \\E &= 0 && \text{on } C_{+z}\end{aligned}\tag{15}$$

where $c = 1/\sqrt{\mu_0\epsilon_0}$. The boundary condition on C_{+z} models a dielectric with a superconductive backing. It is shown in [1] that it is reasonable to expect that each of the remaining three boundary conditions will reflect only approximately 3% of incoming energy. Equation (14), with a rescaling of the time variable by a factor of $c = 1/\sqrt{\epsilon_0\mu_0}$ and a rescaling of P by a factor of $1/\epsilon_0$, then becomes

$$\begin{aligned}\langle \epsilon_r \ddot{E}, \phi \rangle + \langle \ddot{P}, \phi \rangle + \eta_0 \langle \sigma \dot{E}, \phi \rangle + \langle \partial_x(E + V_x), \partial_x \phi \rangle + \langle \partial_z(E + V_z), \partial_z \phi \rangle \\+ \langle (\frac{1}{c}\beta_x + \partial_t)(E + V_x), \phi \rangle_{C_{-x} \cup C_{+x}} + \langle (\frac{1}{c}\beta_z + \partial_t)(E + V_z), \phi \rangle_{C_{-z}} = -\eta_0 \langle \dot{J}_s, \phi \rangle,\end{aligned}\tag{16}$$

where $\eta_0 = \sqrt{\mu_0/\epsilon_0}$ is the impedance of free space.

3 Wellposedness

In this section, we prove that the initial value problem for the variational equation (16) is wellposed. That is, given initial conditions

$$E(0, x, z) = \Phi(x, z), \quad \dot{E}(0, x, z) = \Psi(x, z)\tag{17}$$

we will show that there exists a unique solution of (16), (17) that depends continuously on Φ , Ψ and \dot{J}_s . Without loss of generality we take $\epsilon_r = 1$ in (16).

We now explicitly define the space V of test functions ϕ . This space is given by $V \stackrel{\text{def}}{=} H_R^1(\mathcal{D}) = \{\phi \in H^1(\mathcal{D}) \mid \phi(x, z) = 0 \text{ whenever } (x, z) \in C_{+z}\}$, where $H^1(\mathcal{D}) = \{\phi \in L^2(\mathcal{D}) \mid \nabla \phi \in L^2(\mathcal{D})\}$. Following the approach in [2], we seek solutions $t \rightarrow E(t)$ with $E(t) \in V$, where $t \in [0, T]$. We do this in the context of a Gelfand triple $V \hookrightarrow H \hookrightarrow V^*$ (see [7]). Such an E is known as a weak solution of (16) and is required to satisfy $E \in L^2(0, T; H)$, $\dot{E} \in L^2(0, T; H)$, and $\ddot{E} \in L^2(0, T; V^*) = L^2(0, T; V)^*$. We therefore interpret $\langle \cdot, \cdot \rangle$ to be $\langle \cdot, \cdot \rangle_H$ in all of the terms of (16) except for $\langle \ddot{E}(t), \phi(t) \rangle$ and $\langle \mathcal{J}(t), \phi(t) \rangle = \langle -\eta_0 \dot{J}_s(t), \phi(t) \rangle$, in which case $\langle \cdot, \cdot \rangle$ is given by the duality product $\langle \cdot, \cdot \rangle_{V^*, V}$. We allow $\mathcal{J}(t)$ values in V^* since in our application (see [1]) it is of the form $g(x, t)\delta(z)$.

To rewrite (16) in the form with which we will work, we first express V_x and V_z in convolution form, namely

$$\begin{aligned}V_x(t) &= H_{g_x} E(t) \stackrel{\text{def}}{=} g_x(t) \star E(t), \\V_z(t) &= H_{g_z} E(t) \stackrel{\text{def}}{=} g_z(t) \star E(t),\end{aligned}\tag{18}$$

where

$$\begin{aligned} g_x(t) &\stackrel{\text{def}}{=} ((u_x^{-1}(t) \star u_x^{-1}(t)) - \delta(t)), \\ g_z(t) &\stackrel{\text{def}}{=} ((u_z^{-1}(t) \star u_z^{-1}(t)) - \delta(t)). \end{aligned} \quad (19)$$

The convolution kernels u_x^{-1} and u_z^{-1} are defined in equation (11).

For notational convenience, we define

$$\mathbf{H}_{x,z} = \text{diag}(H_{g_x}, H_{g_z}).$$

Then, given that H_{g_x} and H_{g_z} are constant in x and z respectively on the subregions Ω_k of \mathcal{D} mentioned above, from (18) we have

$$\langle \partial_x V_x, \partial_x \phi \rangle + \langle \partial_z V_z, \partial_z \phi \rangle = \langle \mathbf{H}_{x,z} \nabla E, \nabla \phi \rangle. \quad (20)$$

By definition, β_x is constant on C_{-x} and C_{+x} , and β_z is constant on C_{-z} . In our computations, the PML region is constructed so that the values of β_x on C_{-x} and C_{+x} and β_z on C_{-z} are the same. We will refer to this value on the boundary $C \stackrel{\text{def}}{=} C_{-x} \cup C_{+x} \cup C_{-z}$ by β_c . Our assumption on β_x and β_z also has the result that the operator H_{g_x} on C_{-x} and C_{+x} is identical to H_{g_z} on C_{-z} . In the sequel, we will denote this operator on C with kernel g_c by H_{g_c} .

Using Liebniz's rule and the fact that

$$P(t, x, z) = \int_0^t g(t-s, x, z) E(s, x, z) ds \quad (21)$$

we obtain

$$\ddot{P}(t, x, z) = \int_0^t \ddot{g}(t-s, x, z) E(s, x, z) ds + g(0, x, z) \dot{E}(t, x, z) + \dot{g}(0, x, z) E(t, x, z). \quad (22)$$

We assume that g , \dot{g} , and \ddot{g} are bounded on $[0, T] \times \mathcal{D}$.

Then, given $\lambda(x, z) \stackrel{\text{def}}{=} I_{\mathcal{D}}(x, z) \dot{g}(0, x, z)$, where $I_{\mathcal{D}}$ is the indicator function on \mathcal{D} , there exists $k \geq 0$ such that $\hat{\lambda} = \lambda + k \geq \hat{\epsilon} > 0$. We define a sesquilinear form

$$\sigma_1(\phi, \psi) = \langle \hat{\lambda} \phi, \psi \rangle + \langle \nabla \phi, \nabla \psi \rangle \text{ for } \phi, \psi \in V. \quad (23)$$

It is readily seen that σ_1 is V -continuous and V -elliptic. That is, there are positive constants c_1 and c_2 such that

$$\begin{aligned} |\sigma_1(\phi, \psi)| &\leq c_2 |\phi|_V |\psi|_V \text{ for all } \phi, \psi \in V, \\ \sigma_1(\phi, \phi) &\geq c_1 |\phi|_V^2 \text{ for } \phi \in V. \end{aligned} \quad (24)$$

Finally, combining (23), (22), (20), (18), and (16) we obtain

$$\begin{aligned} &\langle \ddot{E}(t), \phi \rangle + \langle \gamma \dot{E}(t), \phi \rangle + \sigma_1(E(t), \phi) + \left\langle \int_0^t \alpha(t-s) E(s) ds, \phi \right\rangle + \langle \mathbf{H}_{x,z} \nabla E(t), \nabla \phi \rangle \\ &+ \frac{\beta_c}{c} \langle H_{g_c} E(t), \phi \rangle_C + \frac{\beta_c}{c} \langle E(t), \phi \rangle_C + \langle H_{g_c} \dot{E}(t), \phi \rangle_C + \langle \dot{E}(t), \phi \rangle_C = \langle \mathcal{J}(t), \phi \rangle + \langle k E(t), \phi \rangle, \end{aligned} \quad (25)$$

where

$$\alpha(t, x, z) = I_{\mathcal{D}}(x, z)\ddot{g}(t, x, z) \quad \text{and} \quad \gamma(x, z) = I_{\mathcal{D}}(x, z)(\eta_0\sigma(x, z) + g(0, x, z)).$$

Since g and \ddot{g} are bounded on $[0, T] \times \mathcal{D}$ and σ is assumed bounded on \mathcal{D} , so are $\alpha(t)$ and γ . We now prove wellposedness for (25), (17), which implies wellposedness for (16), (17).

Existence

In order to prove the existence of solutions for (25), (17), where $\Phi \in V$ and $\Psi \in H$, we follow closely the general framework found in [2, 4, 5]. We begin by choosing a linearly independent subset $\{w_i\}_{i=1}^{\infty}$ that spans V , and we let $V^m \stackrel{\text{def}}{=} \text{span}\{w_1, \dots, w_m\}$. Define Galerkin ‘‘approximates’’

$$E_m(t, x, z) = \sum_{i=1}^m e_i^m(t)w_i(x, z). \quad (26)$$

The coefficients $\{e_i^m\}$ are determined by solving the linear system that results from replacing E by E_m and ϕ by w_i for $i = 1, \dots, m$ in (25), and taking $E_m(0) = \Phi_m$, $\dot{E}_m(0) = \Psi_m$, where $\Phi_m, \Psi_m \in V_m$ such that $\Phi_m \rightarrow \Phi$ in V , $\Psi_m \rightarrow \Psi$ in H . Taking $\phi = \dot{E}_m$ in equation (25) we then obtain

$$\begin{aligned} & \frac{1}{2} \frac{d}{dt} |\dot{E}_m(t)|_H^2 + |\sqrt{\gamma} \dot{E}_m(t)|_H^2 + \frac{1}{2} \frac{d}{dt} \sigma_1(E_m(t), E_m(t)) + \left\langle \int_0^t \alpha(t-s) E_m(s) ds, \dot{E}_m(t) \right\rangle \\ & + \frac{d}{dt} \langle \mathbf{H}_{x,z} \nabla E_m(t), \nabla E_m(t) \rangle - \langle \partial_t(\mathbf{H}_{x,z} \nabla E_m(t)), \nabla E_m(t) \rangle + \frac{\beta_c}{c} \frac{d}{dt} \langle H_{g_c} E_m(t), E_m(t) \rangle_C \\ & - \frac{\beta_c}{c} \langle \partial_t(H_{g_c} E_m(t)), E_m(t) \rangle_C + \frac{d}{dt} \langle H_{g_c} \dot{E}_m(t), E_m(t) \rangle_C - \langle \partial_t(H_{g_c} \dot{E}_m(t)), E_m(t) \rangle_C \\ & + \frac{\beta_c}{2c} \frac{d}{dt} |E_m(t)|_{L^2(C)}^2 + |\dot{E}_m(t)|_{L^2(C)}^2 = \langle \mathcal{J}(t), \dot{E}_m(t) \rangle + \langle k E_m(t), \dot{E}_m(t) \rangle. \end{aligned} \quad (27)$$

The convolution kernel g_c is given by

$$g_c(t) = -2\beta_c \mathcal{H}(t) e^{-\beta_c t} + \beta_c^2 t \mathcal{H}(t) e^{-\beta_c t}. \quad (28)$$

The kernels g_x and g_z are given by (28) with β_c replaced by $\beta_x(x)$ and $\beta_z(z)$ respectively. Using (28) and integration by parts, we obtain

$$\begin{aligned} \langle H_{g_c} \dot{E}_m(t), E_m(t) \rangle_C &= \langle -\beta_c g_c(t) \star E_m(t), E_m(t) \rangle_C + \beta_c^2 \langle (\mathcal{H}(t) e^{-\beta_c t}) \star E_m(t), E_m(t) \rangle_C \\ & \quad - 2\beta_c \langle E_m(t), E_m(t) \rangle_C - \langle g_c(t) E_m(0), E_m(t) \rangle_C \\ &= \langle -\beta_c g_c(t) \star E_m(t), E_m(t) \rangle_C + \beta_c^2 \langle (\mathcal{H}(t) e^{-\beta_c t}) \star E_m(t), E_m(t) \rangle_C \\ & \quad - 4\beta_c \int_0^t \langle \dot{E}_m(s), E_m(s) \rangle_C ds - 2\beta_c \langle E_m(0), E_m(0) \rangle_C \\ & \quad - \langle g_c(t) E_m(0), E_m(t) \rangle_C. \end{aligned} \quad (29)$$

Integrating (27), using equations (24) and (29), and noting that $\mathbf{H}_{x,z} \nabla E_m(0) = H_{g_c} E_m(0) = H_{g_c} \dot{E}_m(0) = \mathbf{0}$, we have

$$\begin{aligned}
& |\dot{E}_m(t)|_H^2 + 2 \int_0^t |\sqrt{\gamma} \dot{E}_m(s)|_H^2 ds + c_1 |E_m(t)|_V^2 + \frac{\beta_c}{c} |E_m(t)|_{L^2(C)}^2 + 2 \int_0^t |\dot{E}_m(s)|_{L^2(C)}^2 ds \\
& \leq |\dot{E}_m(0)|_H^2 + c_2 |E_m(0)|_V^2 + \left(\frac{\beta_c}{c} + 4\beta_c\right) |E_m(0)|_{L^2(C)}^2 - 2 \langle \mathbf{H}_{x,z} \nabla E_m(t), \nabla E_m(t) \rangle \\
& \quad + 2\beta_c \left(\frac{c-1}{c}\right) \langle g_c(t) \star E_m(t), E_m(t) \rangle_C - 2\beta_c^2 \langle (\mathcal{H}(t)e^{-\beta_c t}) \star E_m(t), E_m(t) \rangle_C \\
& \quad + 2 \langle g_c(t) E_m(0), E_m(t) \rangle_C + 2 \int_0^t F_m(s) ds, \quad (30)
\end{aligned}$$

where

$$\begin{aligned}
F_m(t) &= \langle \mathcal{J}(t), \dot{E}_m(t) \rangle + \langle k E_m(t), \dot{E}_m(t) \rangle + \left\langle - \int_0^t \alpha(t-s) E_m(s) ds, \dot{E}_m(t) \right\rangle \\
& \quad + \frac{\beta_c}{c} \langle \partial_t (H_{g_c} E_m(t)), E_m(t) \rangle_C + \langle \partial_t (\mathbf{H}_{x,z} \nabla E_m(t)), \nabla E_m(t) \rangle \\
& \quad + \langle \partial_t (H_{g_c} \dot{E}_m(t)), E_m(t) \rangle_C + 8\beta_c \langle \dot{E}_m(t), E_m(t) \rangle_C \\
& = F_{m,1}(s) + F_{m,2}(s) + F_{m,3}(s) + F_{m,4}(s) + F_{m,5}(s) + F_{m,6}(s) + F_{m,7}(s).
\end{aligned}$$

We want an upper bound for the left side of (30). To this end, we seek upper bounds for $|\langle \mathbf{H}_{x,z} \nabla E_m(t), \nabla E_m(t) \rangle|$, $|\langle g_c(t) \star E_m(t), E_m(t) \rangle_C|$, $|\langle (\mathcal{H}(t)e^{-\beta_c t}) \star E_m(t), E_m(t) \rangle_C|$, $|\int_0^t F_m(s) ds|$, and $|\langle g_c(t) E_m(0), E_m(t) \rangle_C|$.

To obtain an upper bound for $|\langle \mathbf{H}_{x,z} \nabla E_m(t), \nabla E_m(t) \rangle|$, we first note that by equations (18) and (20),

$$\langle \mathbf{H}_{x,z} \nabla E_m(t), \nabla E_m(t) \rangle = \langle H_{g_x} \partial_x E_m(t), \partial_x E_m(t) \rangle + \langle H_{g_z} \partial_z E_m(t), \partial_z E_m(t) \rangle.$$

We then obtain an upper bound for $|\langle H_{g_x} \partial_x E_m(t), \partial_x E_m(t) \rangle|$.

$$\begin{aligned}
|\langle H_{g_x} \partial_x E_m(t), \partial_x E_m(t) \rangle| &\leq \left| \left\langle \int_0^t g_x(t-s) \partial_x E_m(s), \partial_x E_m(t) \right\rangle \right| \\
&= \left| \int_0^t g_x(t-s) \langle \partial_x E_m(s), \partial_x E_m(t) \rangle ds \right| \\
&\leq c_g \int_0^t |\langle \partial_x E_m(s), \partial_x E_m(t) \rangle| ds \\
&\leq c_g \int_0^t |\partial_x E_m(s)|_H ds |\partial_x E_m(t)|_H \\
&\leq \frac{c_g^2}{4\epsilon} \left(\int_0^t |\partial_x E_m(s)|_H ds \right)^2 + \epsilon |\partial_x E_m(t)|_H^2 \\
&\leq \frac{T c_g^2}{4\epsilon} \int_0^t |\partial_x E_m(s)|_H^2 ds + \epsilon |\partial_x E_m(t)|_H^2,
\end{aligned} \tag{31}$$

where c_g is given by

$$c_g = 2\beta_c + \beta_c^2 T, \quad (32)$$

which is an upper bound for g_c , g_x , and g_z . A computation equivalent to (31) for the z term, combined with (31) yields

$$\begin{aligned} |\langle \mathbf{H}_{x,z} \nabla E_m(t), \nabla E_m(t) \rangle| &\leq \frac{T c_g^2}{4\epsilon} \int_0^t |\nabla E_m(s)|_H^2 ds + \epsilon |\nabla E_m(t)|_H^2 \\ &\leq \frac{T c_g^2}{4\epsilon} \int_0^t |E_m(s)|_V^2 ds + \epsilon |E_m(t)|_V^2. \end{aligned} \quad (33)$$

The second inequality follows from the fact that $|\nabla \phi|_H \leq |\phi|_V$ for $\phi \in V$.

An argument analogous to (31) also yields

$$|\langle g_c(t) \star E_m(t), E_m(t) \rangle_C \leq \frac{T c_g^2}{4\epsilon} \int_0^t |E_m(s)|_{L^2(C)}^2 ds + \epsilon |E_m(t)|_{L^2(C)}^2. \quad (34)$$

and

$$|\langle (\mathcal{H}(t)e^{-\beta_c t}) \star E_m(t), E_m(t) \rangle_C \leq \frac{T}{4\epsilon} \int_0^t |E_m(s)|_{L^2(C)}^2 ds + \epsilon |E_m(t)|_{L^2(C)}^2. \quad (35)$$

Furthermore, we have

$$\begin{aligned} |\langle g_c(t) E_m(0), E_m(t) \rangle_C &\leq c_g |E_m(0)|_{L^2(C)} \cdot |E_m(t)|_{L^2(C)} \\ &\leq \frac{c_g^2}{4\epsilon} |E_m(0)|_{L^2(C)}^2 + \epsilon |E_m(t)|_{L^2(C)}^2. \end{aligned} \quad (36)$$

We obtain an upper bound for $|\int_0^t F_m(s) ds|$ by determining bounds for

$$|\int_0^t F_{m,i}(s) ds|, \quad i = 1, \dots, 7.$$

By arguments found in [2, p. 30],

$$\begin{aligned} |\int_0^t F_{m,1}(s) ds| &\leq \frac{1}{4\epsilon} |\mathcal{J}(t)|_{V^*}^2 + \epsilon |E_m(t)|_V^2 + \frac{1}{2} |\mathcal{J}(0)|_{V^*}^2 + \frac{1}{2} |E_m(0)|_V^2 \\ &\quad + \int_0^t \left\{ \frac{1}{2} |\dot{\mathcal{J}}(s)|_{V^*}^2 + \frac{1}{2} |E_m(s)|_V^2 \right\} ds, \end{aligned} \quad (37)$$

$$\int_0^t |F_{m,2}(s)| ds \leq \int_0^t \left\{ \frac{1}{2} k^2 |E_m(s)|_H^2 + \frac{1}{2} |\dot{E}_m(s)|_H^2 \right\} ds, \quad (38)$$

$$\int_0^t |F_{m,3}(s)| ds \leq K_1 \int_0^t |E_m(s)|_V^2 ds + K_2 \int_0^t |\dot{E}_m(s)|_H^2 ds. \quad (39)$$

Obtaining bounds for the additional terms is tedious, but straightforward. For $\int_0^t |F_{m,4}(s)| ds$ we first note that

$$\langle \partial_t(H_{g_c} E_m(t)), E_m(t) \rangle_C = \langle -2\beta_c E_m(t), E_m(t) \rangle_C + \langle h_c(t) \star E_m(t), E_m(t) \rangle_C, \quad (40)$$

where

$$h_c(t) = 3\beta_c^2 \mathcal{H}(t) e^{-\beta_c t} - \beta_c^3 t \mathcal{H}(t) e^{-\beta_c t}. \quad (41)$$

Hence,

$$\begin{aligned} |\langle \partial_t(H_{g_c} E_m(t)), E_m(t) \rangle_C| &\leq 2\beta_c |E_m(t)|_{L^2(C)}^2 \\ &\quad + |\langle (3\beta_c^2 \mathcal{H}(t) e^{-\beta_c t} - \beta_c^3 t \mathcal{H}(t) e^{-\beta_c t}) \star E_m(t), E_m(t) \rangle_C|, \\ &\leq 2\beta_c |E_m(t)|_{L^2(C)}^2 \\ &\quad + \frac{T(3\beta_c^2 + \beta_c^3 T)^2}{2} \int_0^t |E_m(s)|_{L^2(C)}^2 ds + \frac{1}{2} |E_m(t)|_{L^2(C)}^2. \end{aligned} \quad (42)$$

The second inequality in (42) follows from an argument analogous to (31), with $\epsilon = \frac{1}{2}$. Then

$$\int_0^t |\langle \partial_s(H_{g_c} E_m(s)), E_m(s) \rangle_C| ds \leq (4\beta_c + 1 + T^2(3\beta_c^2 + \beta_c^3 T)^2)/2 \int_0^t |E_m(s)|_{L^2(C)}^2 ds. \quad (43)$$

For $\int_0^t |F_{m,5}(s)| ds$, we note that, analogous to (40),

$$\begin{aligned} \langle \partial_t(\mathbf{H}_{x,z} \nabla E_m(t)), \nabla E_m(t) \rangle &= -\langle 2\beta_x E_m(t), E_m(t) \rangle + \langle h_x(t) \star \partial_x E_m(t), \partial_x E_m(t) \rangle \\ &\quad - \langle 2\beta_z E_m(t), E_m(t) \rangle + \langle h_z(t) \star \partial_z E_m(t), \partial_z E_m(t) \rangle, \end{aligned} \quad (44)$$

where h_x and h_z are defined by (41) with the c replace by x and z respectively. Repeating the arguments found in (42) for the absolute value of both the x and the z terms in the right side of equation (45), and noting that $\beta_x, \beta_z \leq \beta_c$, we obtain

$$\begin{aligned} \int_0^t |\langle \partial_s(\mathbf{H}_{x,z} \nabla E_m(s)), \nabla E_m(s) \rangle| ds &\leq (4\beta_c + 1 + T^2(3\beta_c^2 + \beta_c^3 T)^2)/2 \int_0^t |\nabla E_m(s)|_H^2 ds \\ &\leq (4\beta_c + 1 + T^2(3\beta_c^2 + \beta_c^3 T)^2)/2 \int_0^t |E_m(s)|_V^2 ds. \end{aligned} \quad (45)$$

For $\int_0^t |F_{m,6}(s)| ds$, we use a modification of the arguments found in (42) to obtain

$$\begin{aligned} |\langle \partial_t(H_{g_c} \dot{E}_m(t)), E_m(t) \rangle_C| &\leq 2\beta_c \langle \dot{E}_m(t), E_m(t) \rangle_C \\ &\quad + \epsilon T(3\beta_c^2 + \beta_c^3 T)^2 \int_0^t |\dot{E}_m(s)|_{L^2(C)}^2 ds + \frac{1}{4\epsilon} |E_m(t)|_{L^2(C)}^2. \end{aligned} \quad (46)$$

Then

$$\int_0^t |\langle \partial_t(H_{g_c} \dot{E}_m(s)), E_m(s) \rangle_C| ds \leq \epsilon K_3 \int_0^t |\dot{E}_m(s)|_{L^2(C)}^2 ds + \frac{1 + 2\beta_c}{4\epsilon} \int_0^t |E_m(s)|_{L^2(C)}^2 ds, \quad (47)$$

where $K_3 = 2\beta_c + T^2(3\beta_c^2 + \beta_c^3 T)^2$.

An argument analogous to (36) yields

$$\int_0^t |\langle \dot{E}_m(s), E_m(s) \rangle_C| ds \leq \epsilon \int_0^t |\dot{E}_m(s)|_{L^2(C)}^2 ds + \frac{1}{4\epsilon} \int_0^t |E_m(s)|_{L^2(C)}^2 ds, \quad (48)$$

which gives us a bound for $\int_0^t |F_{m,7}(s)| ds$.

Finally, combining equation (30) with the bounds (33), (34), (35), (36), (37), (38), (39), (43), (45), (47), and (48), we obtain

$$\begin{aligned} & |\dot{E}_m(t)|_H^2 + (c_1 - 4\epsilon)|E_m(t)|_V^2 + \left(\frac{\beta_c}{c} - \epsilon C_1 \right) |E_m(t)|_{L^2(C)}^2 \\ & + 2 \int_0^t |\sqrt{\gamma} \dot{E}_m(s)|_H^2 ds + (2 - \epsilon C_2) \int_0^t |\dot{E}_m(s)|_{L^2(C)}^2 ds \\ & \leq C_m + \int_0^t \{C_3 |\dot{E}_m(s)|_H^2 + C_4 |E_m(s)|_V^2 + C_5 |E_m(s)|_{L^2(C)}^2\} ds, \end{aligned} \quad (49)$$

where C_1, \dots, C_5 are positive constants, and C_m is the constant given by

$$\begin{aligned} C_m = & |\dot{E}_m(0)|_H^2 + (c_2 + 1)|E_m(0)|_V^2 + \left(2\beta_c \frac{c-1}{c} + \frac{2c_g^2}{2\epsilon} \right) |E_m(0)|_{L^2(C)}^2 \\ & + \frac{1}{2\epsilon} |\mathcal{J}(t)|_{V^*}^2 + |\mathcal{J}(0)|_{V^*}^2 + \int_0^t |\dot{\mathcal{J}}(s)|_{V^*}^2 ds. \end{aligned} \quad (50)$$

We choose $\epsilon > 0$ so that the left side of (49) has only positive coefficients.

Recall that $E_m(0) = \Phi_m$, and $\dot{E}_m(0) = \Psi_m$. Hence the sequences $\{E_m(0)\}$ and $\{\dot{E}_m(0)\}$ are bounded in V and H respectively since they converge to Φ and Ψ respectively. Furthermore, we assume that $\mathcal{J} \in H^1(0, T; V^*)$. Then, ignoring the fourth and fifth terms on the left side of (49) and using Gronwall's inequality [7], we conclude that $\{\dot{E}_m\}$ is $C(0, T; H)$ bounded, $\{E_m\}$ is $C(0, T; V)$ bounded, and $\{E_m|_C\}$ is $C(0, T; L^2(C))$ bounded. Finally, substituting these bounds into (49), we find that $\{\dot{E}_m|_C\}$ is $L^2(0, T; L^2(C))$ bounded. Hence, extracting subsequences if necessary, we have that there exists $E \in L^2(0, T; V)$, $\tilde{E} \in L^2(0, T; H)$, $E_C \in L^2(0, T; L^2(C))$, and $\tilde{E}_C \in L^2(0, T; L^2(C))$ such that

$$\begin{aligned} E_m & \rightharpoonup E && \text{weakly in } L^2(0, T; V), \\ \dot{E}_m & \rightharpoonup \tilde{E} && \text{weakly in } L^2(0, T; H), \\ E_m|_C & \rightarrow E_C && \text{weakly in } L^2(0, T; L^2(C)), \\ \dot{E}_m|_C & \rightarrow \tilde{E}_C && \text{weakly in } L^2(0, T; L^2(C)), \end{aligned}$$

where $E|_C$ denotes the function E restricted to the boundary C .

We take E as a candidate for a solution to (25), (17). We first need to show that $\dot{E} = \tilde{E}$, $E|_C = E_C$ on C , and $\dot{E}|_C = \tilde{E}_C$ on C . To this end we note that

$$E_m(t) = E_m(0) + \int_0^t \dot{E}_m(s) ds \quad (51)$$

and

$$E_m(t)|_C = E_m(0)|_C + \int_0^t \dot{E}_m(s)|_C ds. \quad (52)$$

Passing to the limit in the weak H sense yields

$$E(t) = E(0) + \int_0^t \tilde{E}(s) ds, \quad (53)$$

$$E_C(t) = E_C(0) + \int_0^t \tilde{E}_C(s) ds.. \quad (54)$$

From (53) we conclude that $\dot{E} = \tilde{E}$, while (54) implies that $\dot{E}_C = \tilde{E}_C$ on C . Thus, if we can show that $E|_C = E_C$ we are finished. Noting the topological equivalence (see [6, p. 27]) between the standard V inner product and the modified inner product on V defined by

$$\langle \phi, \psi \rangle \stackrel{\text{def}}{=} \langle \phi|_C, \psi|_C \rangle_C + \langle \nabla \phi, \nabla \psi \rangle_{\mathcal{D}}, \quad (55)$$

we see immediately that weak convergence in V implies weak convergence in $L^2(C)$. Thus $E_m \rightarrow E$ weakly in $L^2(0, T; V)$ implies $E_m|_C \rightarrow E|_C$ weakly in $L^2(0, T; L^2(C))$, from which $E|_C = E_C$ follows immediately.

Using Lemma 5.1(b) of [3] we find that in fact E_m converges weakly to E in $C(0, T; H)$, so that $E \in C(0, T; H) \cap L^2(0, T; V)$.

Our candidate E then satisfies

$$E_m \rightarrow E \quad \text{weakly in } L^2(0, T; V), \quad (56)$$

$$\dot{E}_m \rightarrow \dot{E} \quad \text{weakly in } L^2(0, T; H), \quad (57)$$

$$E_m|_C \rightarrow E|_C \quad \text{weakly in } L^2(0, T; L^2(C)), \quad (58)$$

$$\dot{E}_m|_C \rightarrow \dot{E}|_C \quad \text{weakly in } L^2(0, T; L^2(C)). \quad (59)$$

We now must show that E satisfies (25), (17). We follow the argument of [4] and take $\psi \in C^1[0, T]$ with $\psi(T) = 0$, defining $\psi_j(t) \stackrel{\text{def}}{=} \psi(t)w_j$, where $\{w_j\}_{j=1}^\infty$ is defined as above. For fixed j we have that for all $m > j$, E_m must satisfy

$$\begin{aligned} & \int_0^T \left\{ \langle \ddot{E}_m(t), \psi_j(t) \rangle + \langle \gamma \dot{E}_m(t), \psi_j(t) \rangle + \sigma_1(E_m(t), \psi_j(t)) \right. \\ & \quad + \left\langle \int_0^t \alpha(t-s) E_m(s) ds, \psi_j(t) \right\rangle + \langle \mathbf{H}_{x,z} \nabla E_m(t), \nabla \psi_j(t) \rangle + \frac{\beta}{c} \langle H_{g_c} E_m(t), \psi_j(t) \rangle_C \\ & \quad + \frac{\beta}{c} \langle E_m(t), \psi_j(t) \rangle_C + \frac{1}{c} \langle H_{g_c} \dot{E}_m(t), \psi_j(t) \rangle_C + \frac{1}{c} \langle \dot{E}_m(t), \psi_j(t) \rangle_C \left. \right\} dt \\ & = \int_0^T \left\{ \langle \mathcal{J}, \psi_j(t) \rangle + \langle k E_m(t), \psi_j(t) \rangle \right\} dt. \end{aligned}$$

Integrating by parts in the first term, taking the limit as $m \rightarrow \infty$, and the convergences of (56)-(59) yield

$$\begin{aligned}
& \int_0^T \left\{ -\langle \dot{E}(t), \dot{\psi}_j(t) \rangle + \langle \gamma \dot{E}(t), \psi_j(t) \rangle + \sigma_1(E(t), \psi_j(t)) \right. \\
& \quad + \left\langle \int_0^t \alpha(t-s)E(s)ds, \psi_j(t) \right\rangle + \langle \mathbf{H}_{x,z} \nabla E(t), \nabla \psi_j(t) \rangle + \frac{\beta}{c} \langle H_{g_c} E(t), \psi_j(t) \rangle_C \\
& \quad + \frac{\beta}{c} \langle E(t), \psi_j(t) \rangle_C + \frac{1}{c} \langle H_{g_c} \dot{E}(t), \psi_j(t) \rangle_C + \frac{1}{c} \langle \dot{E}(t), \psi_j(t) \rangle_C \left. \right\} dt \\
& = \int_0^T \left\{ \langle \mathcal{J}, \psi_j(t) \rangle + \langle kE(t), \psi_j(t) \rangle \right\} dt + \langle \Psi, \psi_j(0) \rangle.
\end{aligned} \tag{60}$$

Further restricting ψ so that $\psi \in C_0^\infty(0, T)$, we obtain

$$\begin{aligned}
& \int_0^T \dot{\psi}(t) \langle -\dot{E}(t), w_j \rangle dt + \\
& \int_0^T \psi(t) \left\{ \langle \gamma \dot{E}(t), w_j \rangle + \sigma_1(E(t), w_j) + \left\langle \int_0^t \alpha(t-s)E(s)ds, w_j \right\rangle + \langle \mathbf{H}_{x,z} \nabla E(t), \nabla w_j \rangle \right. \\
& \quad + \frac{\beta}{c} \langle H_{g_c} E(t), w_j \rangle_C + \frac{\beta}{c} \langle E(t), w_j \rangle_C + \frac{1}{c} \langle H_{g_c} \dot{E}(t), w_j \rangle_C + \frac{1}{c} \langle \dot{E}(t), w_j \rangle_C \\
& \quad \left. - \langle \mathcal{J}, w_j \rangle - \langle kE(t), w_j \rangle \right\} dt = 0 \tag{61}
\end{aligned}$$

for each w_j . Then, using

$$\frac{d}{dt} \psi(t) \langle \dot{E}(t), w_j \rangle = \dot{\psi}(t) \langle \dot{E}(t), w_j \rangle + \psi(t) \frac{d}{dt} \langle \dot{E}(t), w_j \rangle$$

equation (61) implies that

$$\begin{aligned}
& \frac{d}{dt} \langle \dot{E}(t), w_j \rangle + \langle \gamma \dot{E}(t), w_j \rangle + \sigma_1(E(t), w_j) + \left\langle \int_0^t \alpha(t-s)E(s)ds, w_j \right\rangle \\
& \quad + \langle \mathbf{H}_{x,z} \nabla E(t), \nabla w_j \rangle + \frac{\beta}{c} \langle H_{g_c} E(t), w_j \rangle_C + \frac{\beta}{c} \langle E(t), w_j \rangle_C \\
& \quad + \langle H_{g_c} \dot{E}(t), w_j \rangle_C + \langle \dot{E}(t), w_j \rangle_C = \langle \mathcal{J}, w_j \rangle + \langle kE_m(t), w_j \rangle \tag{62}
\end{aligned}$$

for each w_j . Since $\{w_j\}_{j=1}^\infty$ spans V we therefore have that $\ddot{E} \in L^2(0, T; V^*)$ and that E satisfies (25) for all $\phi \in V$.

From (51) we have $E(0) = \Phi$. To show that $\dot{E}(0) = \Psi$, we return to equation (60). Integration by parts in the first term together with equation (62) yields

$$\langle \dot{E}(t), w_j \rangle \psi(0) = \langle \Psi, w_j \rangle \psi(0) \text{ for all } j.$$

It follows that $\dot{E}(0) = \Psi$, and hence, E is a solution of (25), (17).

Continuous Dependence

The continuous dependence of solutions of (25), (17) on Φ , Ψ , and \mathcal{J} follows from equation (49). We set

$$\begin{aligned} K_m &\stackrel{\text{def}}{=} |\dot{E}_m(0)|_H^2 + (c_2 + 1)|E_m(0)|_V^2 + \left(2\beta_c \frac{c-1}{c} + \frac{2c_g^2}{2\epsilon}\right) |E_m(0)|_{L^2(C)}^2 \\ &\quad + \frac{1}{2\epsilon} |\mathcal{J}|_{L^\infty(0,T;V^*)}^2 + |\mathcal{J}(0)|_{V^*}^2 + \int_0^t |\dot{\mathcal{J}}(s)|_{V^*}^2 ds. \\ &\leq |\dot{E}_m(0)|_H^2 + \mathcal{K}_1 |E_m(0)|_V^2 + \mathcal{K}_2 |\mathcal{J}|_{H^1(0,T;V^*)}^2. \end{aligned} \quad (63)$$

Compare K_m with (50). The inequality (63) follows from an application of the norm relationship resulting from (55). That is, we know there exists a $c > 0$ such that

$$|\phi|_C |_{L^2(C)} \leq c |\phi|_V \quad (64)$$

for all $\phi \in V$. Another application of (64), together with equation (49) yields

$$|\dot{E}_m(t)|_H^2 + |E_m(t)|_V^2 \leq \nu K_m + \int_0^t \nu \{|\dot{E}_m(s)|_H^2 + |E_m(s)|_V^2\} ds, \quad (65)$$

for some $\nu > 0$. Using Gronwall's inequality again, we obtain

$$|\dot{E}_m(t)|_H^2 + |E_m(t)|_V^2 \leq \nu K_m e^{\nu T} \quad \text{for } t \in [0, T]. \quad (66)$$

We note that $\lim_{m \rightarrow \infty} K_m \leq K$ where

$$K = |\Psi|_H^2 + \mathcal{K}_1 |\Phi|_V^2 + \mathcal{K}_2 |\mathcal{J}|_{H^1(0,T;V^*)}^2. \quad (67)$$

Then, via weak lower semicontinuity of norms, the convergences (56) and (57), and (66) we have

$$|\dot{E}|_{L^2(0,T;H)}^2 + |E|_{L^2(0,T;V)}^2 \leq \nu K T e^{\nu T}. \quad (68)$$

Since the mapping $(\Phi, \Psi, \mathcal{J}) \rightarrow (E, \dot{E})$ is linear from $V \times H \times H^1(0, T; V^*)$ to $L^2(0, T; V) \times L^2(0, T; H)$, equations (68) and (67) give us the continuous dependence of solutions (E, \dot{E}) of (25), (17) on the initial data (Φ, Ψ) and \mathcal{J} .

Uniqueness

For uniqueness of solutions to (25), (17) it suffices to show that the only solution of (25) corresponding to zero initial data ($\Phi = \Psi = 0$) and zero input ($\mathcal{J} = 0$) is the trivial solution. Let E be the solution corresponding to $\Phi = \Psi = \mathcal{J} = 0$. Then, passing to the limit in (65) yields

$$|\dot{E}(t)|_H^2 + |E(t)|_V^2 \leq \int_0^t \nu \{|\dot{E}(s)|_H^2 + |E(s)|_V^2\} ds.$$

Gronwall's inequality then implies

$$|\dot{E}(t)|_H^2 + |E(t)|_V^2 \equiv 0.$$

Hence $E(t) \equiv 0$ on $(0, T)$ and solutions of (25), (17) are unique.

We summarize the results of this section in the following theorem. We note that if g , \dot{g} , and \ddot{g} are in $L^\infty([0, T] \times \mathcal{D})$, and $\sigma \in L^\infty(\mathcal{D})$ as assumed above, then γ and α satisfy the conditions of this theorem.

Theorem 3.1 *Suppose that $\mathcal{J} \in H^1(0, T; V^*)$, $\gamma \in L^\infty(\mathcal{D})$, and $\alpha \in L^\infty(0, T; L^\infty(\mathcal{D}))$ with α and γ vanishing outside of \mathcal{D} . In addition, suppose that the PML parameters β_x and β_z are piecewise constant, convex with maximum value β_c on the boundaries $C_{-x} \cup C_{+x}$ and C_{-z} respectively. Then for $\Phi \in V = H_R^1(\mathcal{D})$, $\Psi \in H = L^2(\mathcal{D})$, we have that solutions to (25), (17) exist and are unique. These solutions satisfy $E \in L^2(0, T; V) \cap C(0, T; H)$, $\dot{E} \in L^2(0, T; H)$, and $\ddot{E} \in L^2(0, T; V^*)$, and depend continuously on $(\Phi, \Psi, \mathcal{J})$ as maps from $V \times H \times H^1(0, T; V^*)$ to $L^2(0, T; V) \times L^2(0, T; H)$.*

4 Conclusions

The theoretical results established here provide a rigorous foundation for the system investigated computationally in [1]. New arguments to handle the PMLs in the context of a multidimensional system with finite antenna, current generated microwave pulses are given. Similar formulations should provide a framework for a convergence and error analysis of the finite element, PML computational methods developed in [1].

5 Acknowledgements

This research was supported in part by the U.S. Air Force Office of Scientific Research under grant AFOSR F49620-01-1-0026 and in part by the National Science Foundation under grant DMS-0112069 to the Statistical and Applied Mathematical Sciences Institute.

References

- [1] H. T. Banks, Brian L. Browning. *Time domain electromagnetic scattering using finite elements and perfectly matched layers* CRSC Tech. Report TR02-22, NC State Univ. July 2002; revised June 2003; Comp. Meth. Appl. Mech. Eng., submitted.
- [2] H. T. Banks, M. W. Buksas, and T. Lin. *Electromagnetic Material Interrogation Using Conductive Interfaces and Acoustic Wavefronts*. SIAM, Philadelphia, 2000.
- [3] H. T. Banks, D. S. Gillian, and V. I. Shubov. Global solveability for damped abstract nonlinear hyperbolic systems. *Differential and Integral Equations*, 10:309–332, 1997.

- [4] H. T. Banks, K. Ito, and Y. Wang. Wellposedness for damped second order systems with unbounded input operators. *Differential and Integral Equations*, 8:587–606, 1995.
- [5] H. T. Banks, R. C. Smith, and Y. Wang. *Smart Material Structures: Modeling, Estimation and Control* Masson/John Wiley, Paris/Chichester, 1996.
- [6] V. G. Maz'ja. *Sobolev Spaces*. Springer-Verlag, Berlin, 1985.
- [7] J. Wloka. *Partial Differential Equations*. Cambridge University Press, Cambridge, 1987.